



**BIRDS-X ICD v1.0**  
**BIRDS-X APRS Payload Competition**  
**Interface Control Document (ICD)**  
Satellite Interfaces and Configuration



Laboratory of Lean Satellite Enterprises and In Orbit Experiments

Kyushu Institute of Technology

Kitakyushu 804-8550, Japan

<https://kyutech-laseine.net/english/>



## Contents

Acronyms.....	5
Units.....	6
BIRDS-X Introduction and Scope.....	7
Related Documents.....	8
BIRDS-X Platform Outline .....	9
BIRDS-X System Diagram.....	10
BIRDS-X Satellite Dimension.....	11
Payload Requirements .....	13
Mechanical Interface.....	13
Electrical Interface .....	16
Data Transfer Interface .....	19
Notes.....	20



## List of figures

Figure 1. APRS payload competition phases .....	7
Figure 2 Schedule for APRS Payload Competition.....	8
Figure 3 Internal configuration of the satellite .....	9
Figure 4 System Diagram of the satellite .....	10
Figure 5 Bottom view of the satellite .....	11
Figure 6 External view of the satellite.....	12
Figure 7 Internal configuration of the satellite .....	12
Figure 8 APRS payload board size requirements: top view .....	14
Figure 9 APRS payload board size requirements: front view .....	14
Figure 10 APRS payload board size requirements: side view.....	15
Figure 11 Isometric view of the payload .....	16
Figure 12 Bottom view of the payload .....	16
Figure 13 Pin number 1 assignment .....	18
Figure 14 Implementation of switch for power tapping .....	19

## List of Table

Table 1 Satellite dimensions.....	11
Table 2 Pin assignment for the APRS payload board .....	17



## Acronyms

2U CubeSat	2-Unit CubeSat
AF	Audio Frequency
AFSK	Audio Frequency-Shift Keying
API	Application Programming Interface
APRS	Automatic Packet Reporting System
ARDC	Amateur Radio Digital Communications
BIRDS	Joint Global Multi-Nation Birds Satellite project
BPB	Backplane Board
CAD	Computer-Aided Design
COMM	Communication System
COTS	Commercial-Off-The-Shelf
CPLD	Complex Programmable Logic Device
DIO	Digital Input/Output
EM	Engineering Model
EPS	Electrical Power System
FAB	Front Access Board
FM	Flight Model
FM	Flash Memory
FM	Frequency Modulation
GND	Ground
GS	Ground Station
GT	Ground Terminal
ICD	Interface Control Document
ISS	International Space Station
J-SSOD	JEM Small Satellite Orbital Deployer
JAXA	Japan Aerospace Exploration Agency
Kyutech	Kyushu Institute of Technology
MCU	Microcontroller Unit
OBC	On Board Computer
OCP	Overcurrent Protection
PCB	Printed Circuit Board
RAB	Rear Access Board
RF	Radio Frequency
RGS	Reference Ground Station
RGT	Reference Ground Terminal
Rx	Receive



SPI	Serial Peripheral Interface
TNC	Terminal Node Controller
TRX	Transceiver
Tx	Transmit
UART	Universal Asynchronous Receiver-Transmitter
UHF	Ultra-High Frequency
VHF	Very High Frequency

## Units

bps	Bits Per Second
g	Gram
mA	Milliampere
MHz	Megahertz
mm	Millimeter
W	Watt
Wh	Watt-Hour
V	Volt
mAh	Milliampere Hour



# BIRDS-X Introduction and Scope

BIRDS-X project is a 2U CubeSat (100mm x 100mm x 226.5mm) dedicated to amateur radio communication. Our stakeholders are Kyushu Institute of Technology (Kyutech) and the Association for Radio Digital Communications (ARDC). The goal of our project is to bring diversity to the space sector and democratize the usage of space.

One of the missions in the BIRDS-X satellite project is to select five Automatic Packet Reporting System (APRS) Payload designs through open competition. The objective of the APRS payload competition is increasing the users of amateur radio community, as well as helping people to get involved in the design, development, and operation of that payload, resulting in the improvement of technical skills and democratization of space.

The mission aims to fulfill the objectives linked to APRS communication: creating outreach for the radio amateur community and developing the APRS technology in space to improve its accessibility. By having a public competition, we aim to engage a maximum number of participants with amateur radio communication and at the same time to stimulate the development of communication technology.

The competition will be held in three phases as shown in Figure 1. Qualifying teams from first phase will progress to development of payload for next phases until five final APRS payloads are selected to be launched in the BIRDS-X satellite.

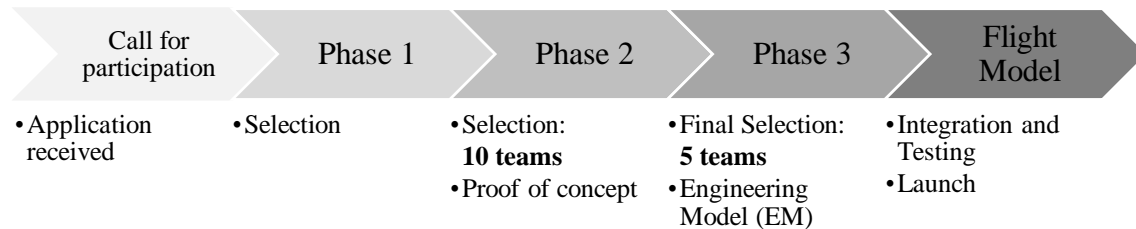
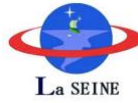

Figure 1. APRS payload competition phases

The timeline for payload development will be according to the schedule shown in Figure 2. At the end of the competition, the selected teams will have to deliver a fully functional APRS payload board. The payload must comply to all the requirements mentioned in this Interface Control Document (ICD) that will allow easy integration of the payload to the satellite.



TASK	2023											
	JAN	FEB	MAR	APR	MAY	JUN	JUL	AUG	SEP	OCT	NOV	DEC
<b>1st Phase</b>												
Call for participation	█	█	█	█	█	█	█	█	█	█	█	█
Application submission deadline			█									
Evaluation period			█	█	█	█	█	█	█	█	█	█
Announcement of selected teams			█	█	█	█	█	█	█	█	█	█
<b>2nd Phase</b>												
Development period			█	█	█	█	█	█	█	█	█	█
Submission of documents					█	█	█	█	█	█	█	█
Evaluation period					█	█	█	█	█	█	█	█
Announcement of selected 10 teams						█	█	█	█	█	█	█
<b>3rd Phase</b>												
Engineering model development						█	█	█	█	█	█	█
Submission of engineering model									█	█	█	█
Evaluation period									█	█	█	█
Announcement of selected 5 teams										█	█	█
Flight model development											█	█
Submission of flight model												█

Figure 2 Schedule for APRS Payload Competition

## Related Documents

1. BIRDS Platform ICD, Rev. F, March 2021.
2. ISO 17770:2017, Space Systems – Cube satellites
3. JEM Payload Accommodation Handbook, Vol.8 Rev. D1, July 2020.
4. ISO/TC20/SC14/WG1 “Space Systems – CubeSat Interface”, Working Draft, November 2020.
5. CubeSat bus interface with Complex Programmable Logic Device, Acta Astronautica, 160(2019), 331–342.
6. ISO 19683:2017, Space Systems – Design qualification and acceptance tests of small spacecraft and units



## BIRDS-X Platform Outline

BIRDS-X satellite architecture is divided into two sections: the BUS and the mission payloads. The BUS is comprised of the:

1. On-Board Computer (OBC/EPS)
2. Battery Box
3. Front Access Board (FAB)
4. Rear Access Board (RAB)
5. Communication Board (UHF Transceiver)
6. Back Plane Board (BPB)
7. Antenna Panel Board

Figure 3 shows the internal configuration and layout of the BIRDS-X satellite platform.

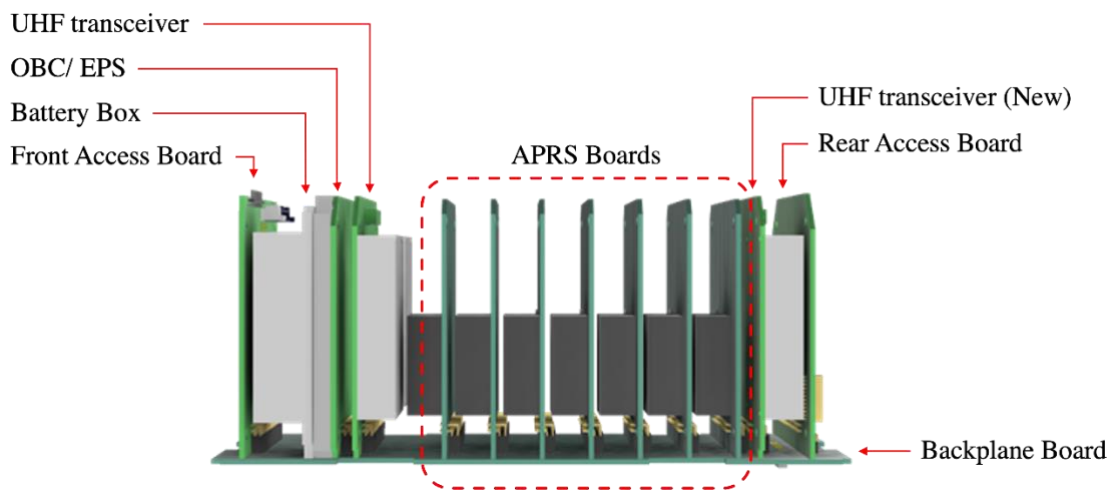

Figure 3 Internal configuration of the satellite

The platform uses a backplane to provide electrical and mechanical interface to the internal boards. The backplane consists of 50-pin female connectors (A3C-50DA-2DSA) for BUS system and payloads to be plugged to the backplane for integration.







## BIRDS-X Satellite Dimension

The dimensions of the BIRDS-X satellite are detailed in Table 1.

Table 1 Satellite dimensions

Size	Satellite dimensions [mm]	Rail dimension [mm]	Tolerance [mm]
2U	(X, Y, Z): (100, 100, 227)	8.5 x 8.5	$\pm 0.1$

The dimension of the platform conforms to CubeSat standard. The  $\pm Z$  rail ends and the edges of the rail sides are rounded at 1 mm radius of curvature. Also, the rail surface conforms to MIL-A-8625 Type3; hard anodized coating has been made at 10  $\mu\text{m}$  or more. The coordinate system of the BIRDS-X platform conforms to the CubeSat deployment system (J-SSOD-R, E-SSOD, etc.) and defined as follows:

1. The coordinate system of the platform: (X, Y, Z)
2. The origin is at the geometric center in the nominal dimensions of the platform.

Figure 5 to Figure 7, show the CAD images of the CubeSat along with the coordinate system.

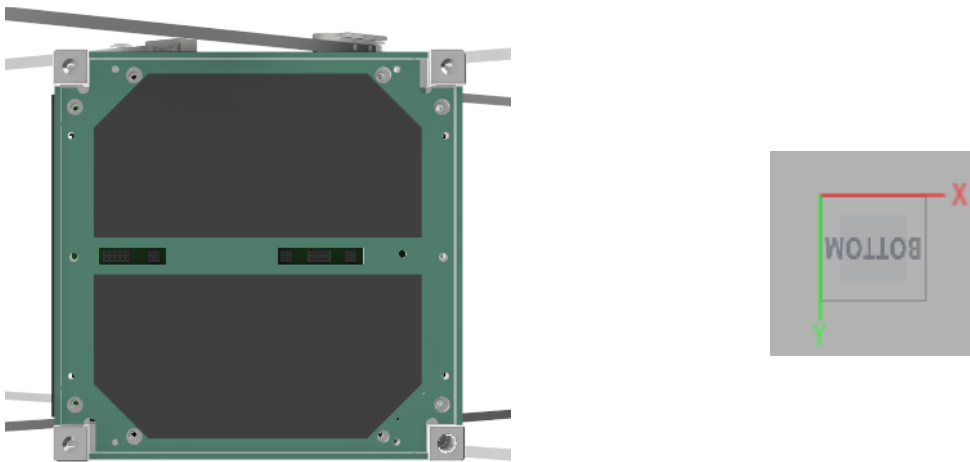

Figure 5 Bottom view of the satellite

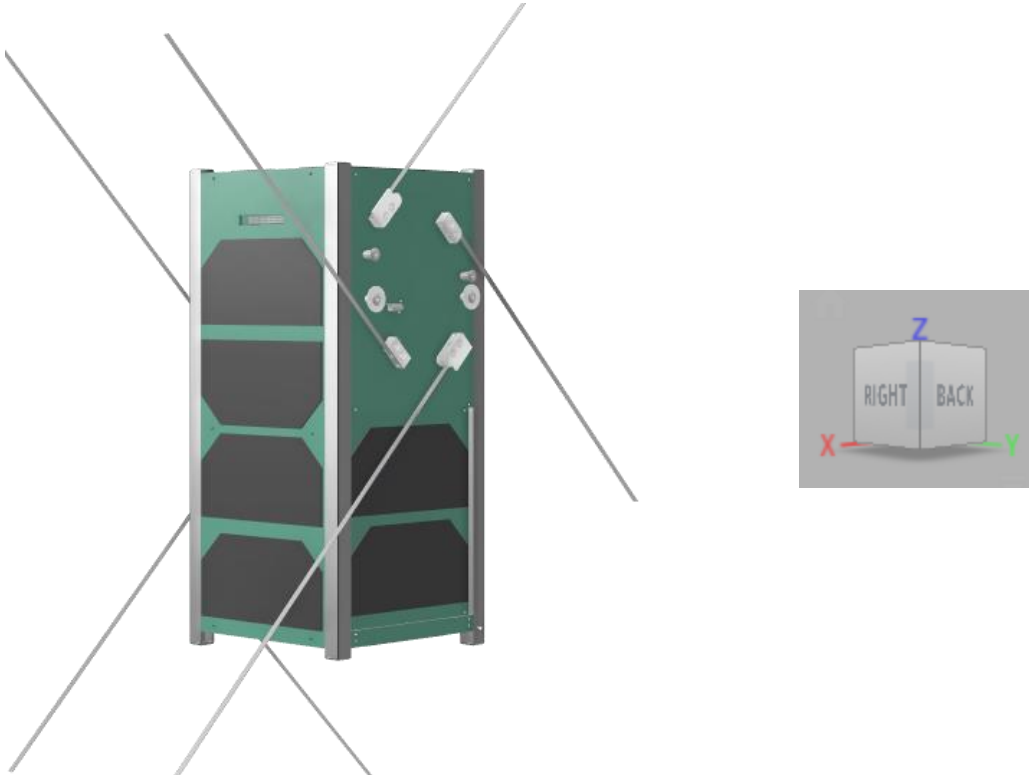

Figure 6 External view of the satellite



Figure 7 Internal configuration of the satellite



# Payload Requirements

## Mechanical Interface

The APRS payload must be designed with the dimensions detailed in Figure 8 to Figure 10. The dimensions of the APRS payload board must be 85mm x 85mm and must use a 50-pin male connector (NRPN252PARN-RC, LPC- 50M2LG, or equivalent) for connection with the backplane. In addition, the platform secures each board with four rods. Therefore, 3.8mm diameter holes must be included at four corners of the board for passing the long rods.

The maximum thickness of the payload board must not exceed 12mm excluding the 1.6mm thickness of the PCB board, which gives a total of 13.6mm. The sizes and positions of the boards as well as the position of the 50-pin connector is detailed in Figure 8. The antenna connector must be right angle MCX connector (60611002111502 from Würth Elektronik, or equivalent) and must be placed on the right bottom edge of the payload as detailed in Figure 8 and illustrated in Figure 11.

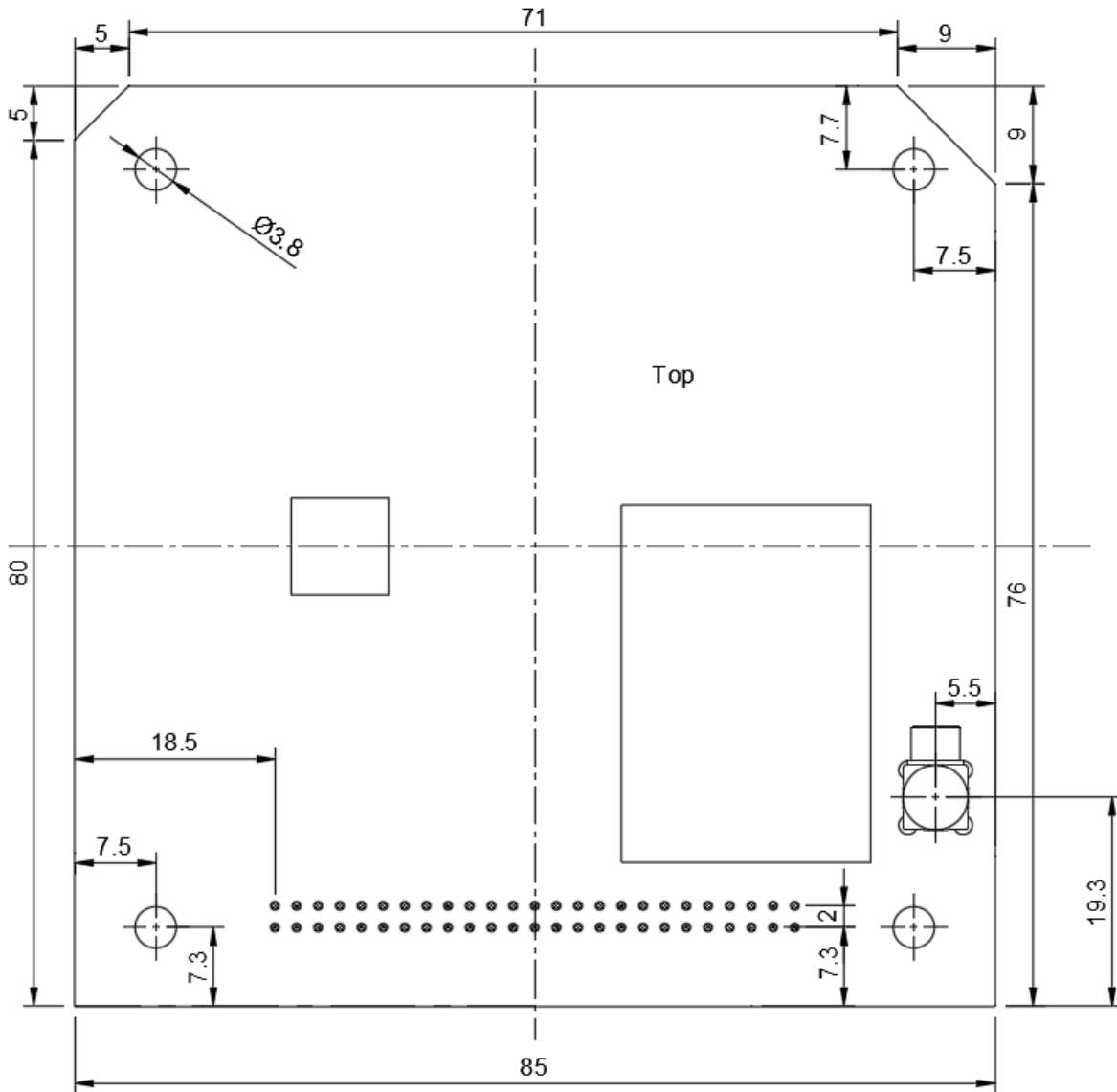

Figure 8 APRS payload board size requirements: top view

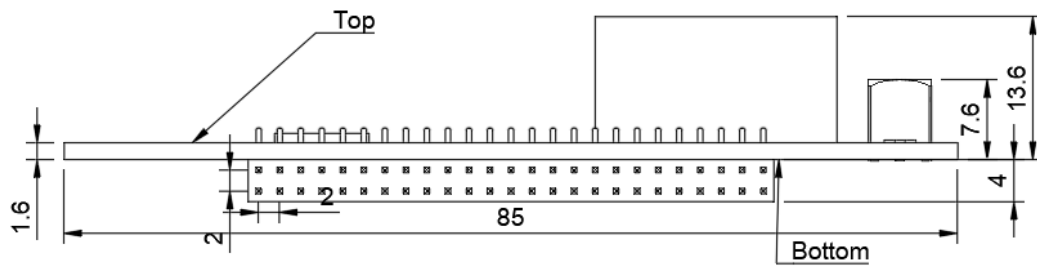

Figure 9 APRS payload board size requirements: front view

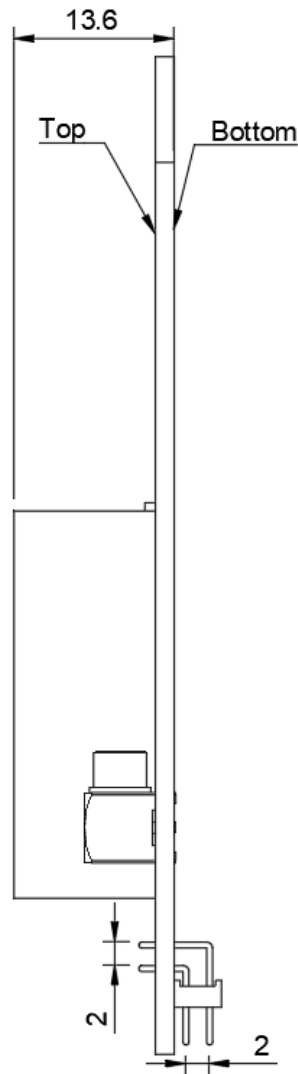

Figure 10 APRS payload board size requirements: side view

All the components must be placed on the top side of the PCB as Figure 8, the side which has the larger cut at the top right corner. The 50-pin male connector must be soldered on the bottom side of the PCB. The pin assignment of the 50-pin connector is detailed in the next sub-section.

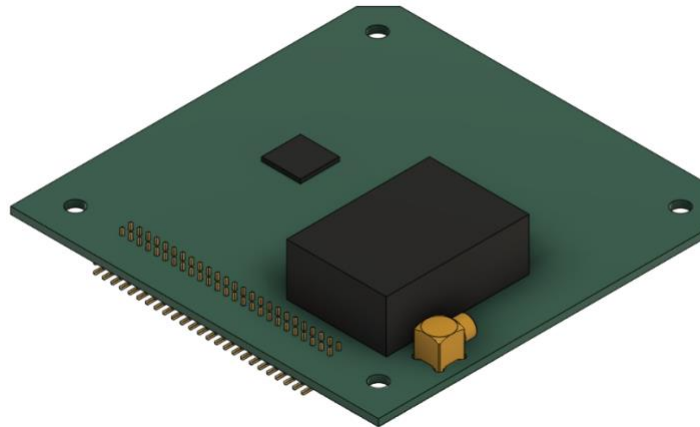

Figure 11 Isometric view of the payload

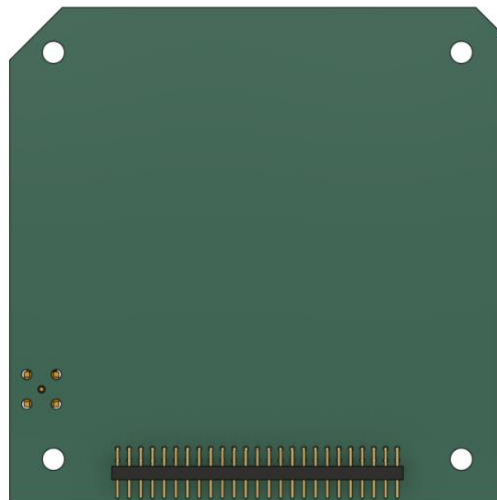

Figure 12 Bottom view of the payload

The dimensions are subjected to minor changes, for any changes made, it will be notified, and will be included in the next versions of the ICD. Please check the website for latest version of the ICD.



## Electrical Interface

### 1. Pin Assignment

The pin assignment for 50-pin connector (NRPN252PARN-RC, LPC- 50M2LG, or equivalent) on the APRS payload board must follow the assignment as shown in Table 2.





Table 2 Pin assignment for the APRS payload board

Signal Name	Pin Number		Signal Name
Programming/debug #2	2	1	Programming/debug #1
	4	3	Programming/debug #3
	6	5	
	8	7	
	10	9	
	12	11	
GND_SYS	14	13	GND_SYS
SUP_5V0	16	15	SUP_5V0
UART (APRS-MissionBoss)	18	17	UART (MissionBoss- APRS)
DI/O_2 (MissionBoss-APRS)	20	19	DI/O_1 (MissionBoss-APRS)
	22	21	
SUP_UNREG_1	24	23	SUP_UNREG_1
SUP_3V3_2	26	25	SUP_3V3_2
	28	27	
	30	29	
	32	31	
	34	33	
SUP_UNREG_2	36	35	SUP_UNREG_2
	38	37	
	40	39	
	42	41	
	44	43	
	46	45	
	48	47	
SUP_3V3_1	50	49	SUP_3V3_1





The legend for connection type is as shown below:

	Digital connection (fixed)
	Digital connection (configurable through CPLD)
	Analog connection
	Power connection

Pin number 1 on the payload board is as marked in the following Figure 13. In order to avoid confusion, the cuts on the top corners are made asymmetrical. The pin number 1 is the upper first pin from the left on the 50-pin connector when the shorter cut corner is on the top left-hand side.

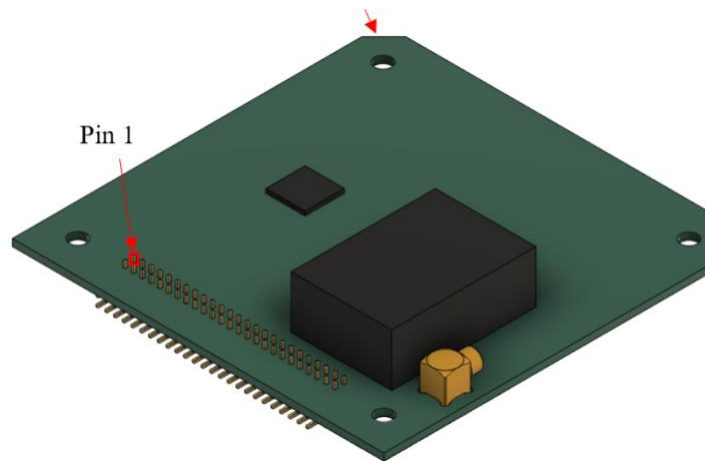

Figure 13 Pin number 1 assignment

## 2. Power Lines

The payload can use two power lines from the BUS system; 3.3V line (pin number 25 and 26) and 5V line (pin 15 and 16) from 50-pin connector to power the board. Before tapping the power lines to power the APRS payload, a switch preferably an overcurrent protection (OCP) with an enable pin for example LTC4361 or equivalent must be implemented for each power line as shown in Figure 14. The enable line of OCP for 3.3V line must be routed to pin number 19 and for 5V line must be routed to pin number 20 on the 50-pin connector. This allows the BUS to control the operation of the APRS payload on-orbit. Any part of the payload **MUST NOT** operate before the implementation of OCP. If any team decides to use either 3.3V or 5V then only one switch can be implemented on the board following the pin assignment for each kind of enable line.

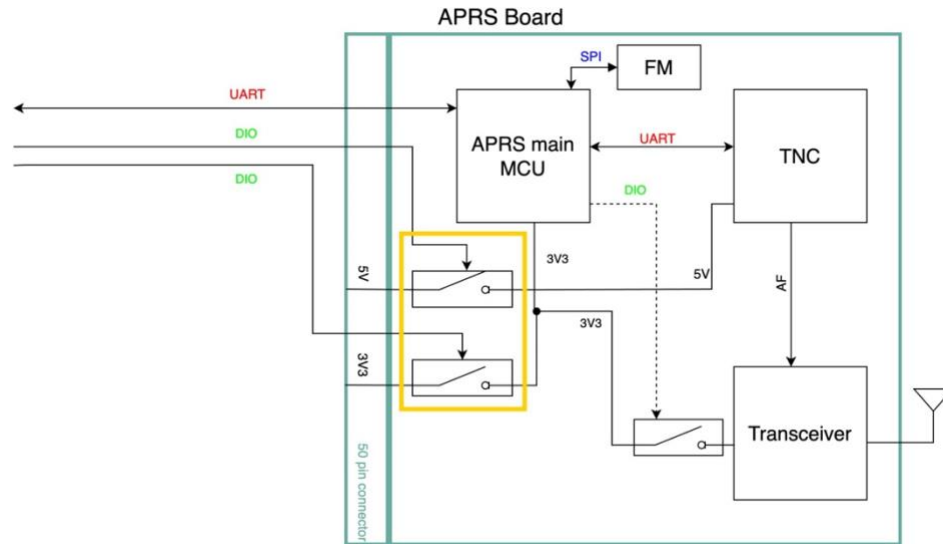

Figure 14 Implementation of switch for power tapping

The power consumption of the design of the APRS payload must not exceed **200mW** during receive mode and **3000mW** during transmit mode.

### Data Transfer Interface

The APRS payload will communicate and transfer mission data to Mission Boss using UART protocol at a baud rate of 9600bps. Pin number 17 and 18 of the 50-pin connector are assigned for the UART communication; Pin 17 for Rx (Mission Boss to APRS) and Pin 18 for Tx (APRS to Mission Boss). Pin number 1-3 are assigned for programming of the main microcontroller unit (MCU) through the external access ports once the satellite is assembled.

Figure 14 also shows a typical example of APRS payload board. The APRS payload must be a modular system; it must be able to decode the APRS packets received from ground terminals in AX.25 protocol and store the received packets in its own flash memory during mission execution. The stored mission data must be transferred to the Mission Boss only through UART communication. Since the programming lines are only provided for the APRS main MCU, the call sign for the TNC must be able to be updated through a command from the APRS main MCU.



The payload shall work in two mission modes:

- Digipeater: RF signals containing APRS messages from amateur radio users or ground terminals shall be received by the transceiver, decoded by the TNC, and sent back to Earth immediately. These messages are not stored on the flash memory.
- Store and Forward: RF signals containing APRS messages are decoded by the TNC, sent back to Earth and at the same time are saved on the flash memory. The stored data packets will be transferred to the mission boss and later downloaded to the ground station for analysis.

The participants could add sensors to the payload design as long as it complies with the power budget, mass and volume requirements. The data collected from the sensors can be communicated to the mission boss only through the UART communication.

## Notes

1. Each APRS payload must be able to survive space environment. Although the space environment tests will be performed at Kyutech, the components selected for the payload board must be able to operate within the temperature range of  $-15^{\circ}\text{C}$  to  $+55^{\circ}\text{C}$ .
2. Each APRS payload shall make no harm to the rest of the satellite and its components, such as other APRS payloads and the satellite bus system, during its nominal operation and even during faulty conditions.
3. Each APRS payload must be delivered with an Application Programming Interface (API). The team is also required to develop software for the designed payload. The commands for activating the mission will be provided in detail in the next version of the ICD. The payload will not be considered as “delivered” without a working software.
4. Functional tests reports and test environment will be required to be submitted for the designed payload.
5. The selected team for FM submission will have the opportunity to use the payload after the execution of the on-orbit competition, this will be subjected to coordination with the BIRDS-X team in advance.

### IMPORTANT

**The ICD will be updated as needed throughout the period leading up to the selection of five payload boards. The up-to-date version will be maintained in the BIRDS-X Project Website (<https://birds-x.birds-project.com>). All participants are responsible for working with the correct version by checking the revision date.**



**Laboratory of Lean Satellite Enterprises and In Orbit Experiments Kyushu Institute  
of Technology**

**Kitakyushu 804-8550, Japan**

<https://kyutech-laseine.net/english>



**BIRDS-X Satellite Project - KyuTech**



**birdsx\_satellite\_project**



**BIRDS-X Satellite Project**